



PowerSystems

500W/1000W

TRANSFORMATOR - TRANSFORMER

NO Monteringsanvisning

GB Installation guide



www.defa.com

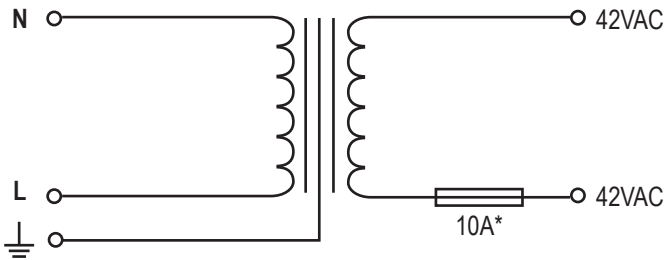
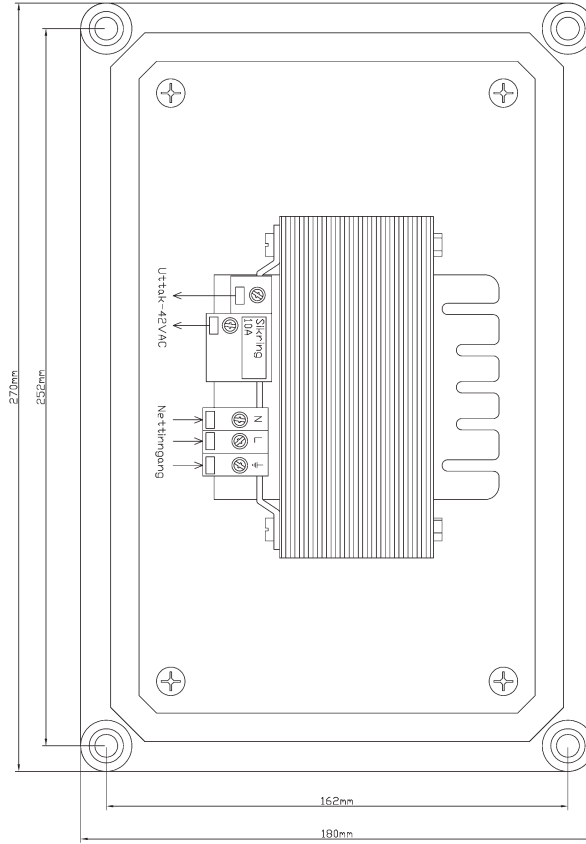

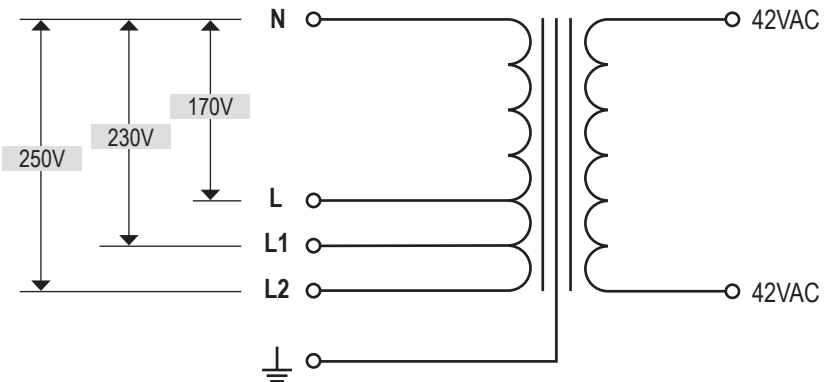
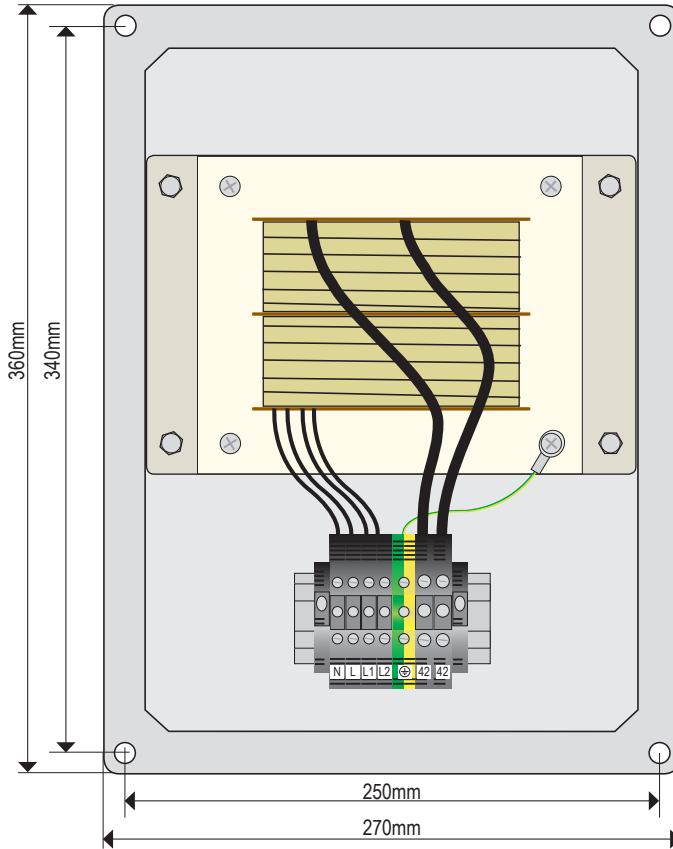

SIKKERHET

Ta deg tid til å lese manualen. Skade på utstyr og personer kan være resultatet dersom utstyret installeres feil. Er det usikkerhet vedrørende montering av utstyr: ta kontakt med oss, en av våre forhandlere eller autorisert installatør.

Kontroller alltid at spenningen er riktig ut fra transformatoren før laderen og annet utstyr tilkobles.

SIKKERHETSTRANSFORMATOR

SOLAS reglementet har satt høyeste spenning til 55V ombord i livbåter. Det må derfor brukes en "step down" transformator fra skipets system-spenning og ned til livbåtens inntakspenning. Denne "safetytransformer" er med på å gjøre opphold i og rundt livbåten mindre farlig i en kritisk situasjon. Tetthetsgrad er IP65.

500W	1000W
<p>Nettspenning kobles til terminal N og L. Beskyttelsesjord kobles til terminal merket med GND eller jord symbol. 42V uttaket føres videre til N og L på batteriladeren.</p>	<p>Nettspenning. Kobles til terminal N and L1. Lavspenning: Koble sammen N og L. Høyspenning: Koble sammen N og L2. Beskyttelsesjord kobles til terminal merket med GND eller jord symbol. 42V uttaket føres videre til N og L på batteriladeren.</p>

	500W				1000W
DEFA art. nr:	701666	700466	700470	701406	700467 /68 /69
Ladac nr:	4040OM400	4040OM	4040OM440	4040OM110	4040OM1000
Inn Spenning [VAC]	400	230	380/440**	110	170/230/250*
Ut Spenning [VAC]	42				
Dim (HxWxD)[mm]	270x180x180				360x270x180
Tetthet [IP]	65				
Vekt [kg]	9,5				19

* Alternative inn spenninger 170V/230V/250V.

** Alternative inn spenninger 380V/440V.



Fyll ut skjema og send dette til oppgitt adresse FØR du returnerer produktet.

Adresse:

DEFA PowerSystems

Merk: "Support"
Blingsmoveien 30
N-3540 Nesbyen
Norge

Alternativt kan du sende den samme informasjonen nedenfor i e-post til **defa_powersystems@defa.com**.
Sett inn forhandlernavn og produktnummer i "Subject" felt i e-posten.

• Hvor ble varen kjøpt?

• Postnummer: _____ • Poststed: _____

• Når ble varen kjøpt? _____

• Vare-Typebetegnelse: _____

• Vare - Serienummer (snr): _____

• Beskriv feilen: _____

• Hvor lenge har produktet vært i drift? _____

• Beskriv bruksområde: _____

• Er følgende punkter sjekket?:

Les manualen FØR montering.

Montasje/tilkobling av lader skal kun skje med komponenter som medfølger.

Montasje /tilkobling av ladere som forutsetter tilkobling til 230V skal kun utføres av godkjent personell.

DEFA PowerSystems ansvar begrenser seg til verdien på varen. Retur av varen er på kjøpers regning og risiko.

• Dato: _____

• Kontaktpers./Sign.:

SAFETY

Take time to read the manual. Equipment damage and possible injuries may result from an incomplete understanding of the installation and operation of the charger. If you are unfamiliar with electrical systems: consult us, a dealer or a licensed electrician.

Make sure that the inverte out voltages correct before conneting other equipement.

SAFETY TRANSFORMER

SOLAS regulations specify a maximum voltage of 55V aboard lifeboats. This means a "step down" transformer needs to be used from the vessel power supply down to the intake voltage of the lifeboat. This "safety transformer" is installed to make being in and around the lifeboat less dangerous in an emergency situation. IP65 encapsulation standard.

500W	1000W
Connect Voltage to terminal N and L . Connect Protective Earth to terminal GND or earth symbol terminal. Gate the 42V outlet to N and L on the battery charger .	Connect Voltage to terminal N and L1 . Low Voltage: Connect N and L together. High Voltage: Connect N and L2 together. Connect Protective Earth to terminal GND or earth symbol terminal. Gate the 42V outlet to N and L on the battery charger .

	500W				1000W
DEFA Item no:	701666	700466	700470	701406	700467 /68 /69
Ladac no:	4040OM400	4040OM	4040OM440	4040OM110	4040OM1000
In Voltage [VAC]	400	230	380/440**	110	170/230/250*
Out Voltage [VAC]	42				
Dim (HxWxD)[mm]	270x180x180				360x270x180
IP rating	65				
Weight [kg]	9,5				19

* Alternativ In voltage 170V/230V/250V.

** Alternativ In voltage 380V/440V.



FILL OUT THIS CLAIM FORM



Sheet for claim to be sent to DEFA PowerSystems PRIOR to return of product.

Address:

DEFA PowerSystems
Att: "Support"
Blingsmoveien 30
N-3540 Nesbyen
Norway

Alternatively send us the same information in a e-mail to **defa_powersystems@defa.com**.
Fill in your customer name and the applicable product name in the subject field.

<ul style="list-style-type: none"> • Where did you purchase the product? _____ • Postal code: _____ • City: _____ • Date of purchase? _____ • Product -Type: _____ • Product - Serial no.(snr): _____ • Describe malfunction: _____ • Time in use? _____ • Describe type of application: _____ 	<ul style="list-style-type: none"> • Have you performed this check points?: Read manual before use. Use only components enclosed. Only authorized personnel are allowed to connect 230V. DEFA PowerSystems liability is limited to the value of the order. DEFA is not to be liable for any consequential losses. • Date: _____ • Contact name./Sign: _____
--	---



PowerSystems



DEFA AS

PowerSystems
Blingsmavn. 30. N-3540 Nesbyen

☎ +47 63 00 20 00

☎ +47 63 00 20 01

✉ defa.powersystems@defa.com



INTELLITEC MV Ltd.

AIZLEWOOD 'S MILL, NURSERY STREET
SHEFFIELD, S3 8GG, UNITED KINGDOM

☎ +44 (0) 114 282 3326

☎ +44 (0) 114 282 3398

✉ DH@INTELLITECMV.COM

WWW.INTELLITECMV.COM



Machinery Ltd.

Ansatie 5 - 01741 Vantaa, FINLAND

☎ +358 2 276 4444

☎ +358 2 238 8963

✉ kalle.fontell@machinery.fi

WWW.MACHINERY.FI



GENETECH Ltd.

5 MALLORY LANE - STAMFORD
LINCOLNSHIRE PE9 2FW, UNITED KINGDOM

☎ +44 (0) 1780-767797

☎ +44 (0) 1780-767798

✉ DICK@GENETECHLTD.CO.UK



World Trade Auto

C. Motors 310-312 - 08908 L'Hospitalet
Barcelona, SPAIN

☎ +34 93-263 01 25

☎ +34 93-335 35 88

✉ wta@worldtradeauto.com

WWW.WORLDTRADEAUTO.COM



REAL S.p.A.

CORSO FRANCIA 327 - 10096 COLLEGNO
PO BOX 32 COLLEGNO (TO), ITALY

☎ +39 011 415 8811

☎ +39 011 415 8812

✉ INFO@REALAUTO.IT

WWW.REALAUTO.IT



Southern Pumps S.A. (Pty) Ltd.

P.O. Box 519 - Milnerton 7435
48 Marconi Road - Montague Gardens
7405

REPUBLIC OF SOUTH AFRICA

☎ +021 551 2490

☎ +021 551 3088

✉ graham.crowley@southernpumps.co.za

WWW.WORLDTRADEAUTO.COM



Power Supply Europe B.V

P.O. BOX 215
8860 AE- HARLINGEN, NETHERLANDS

☎ +31 (0) 517 433480

☎ +31 (0) 517 418412

WEB: WWW.POWERSUPPLYEUROPE.NL

✉ INFO@POWERSUPPLYEUROPE.NL



FRIIS ELECTRONIC

GSCHWANDNERGASSE 59
AT - 1170 VIENNA, AUSTRIA

☎ +43 1 480 20 20

☎ +43 1 480 21 00

✉ FRIIS@EUNET.AT

WWW.FRIIS.AT

www.defa.com

700777 E11 - CE 130514